

PART NO.	DIM. "A"	DIM. "B"	DIM. "C"
WS-SE2-1-01	16.6 [.65]	10.5 [.41]	7.1 [.28]
WS-SE2-2-01	19.5 [.77]	13.4 [.53]	10 [.39]

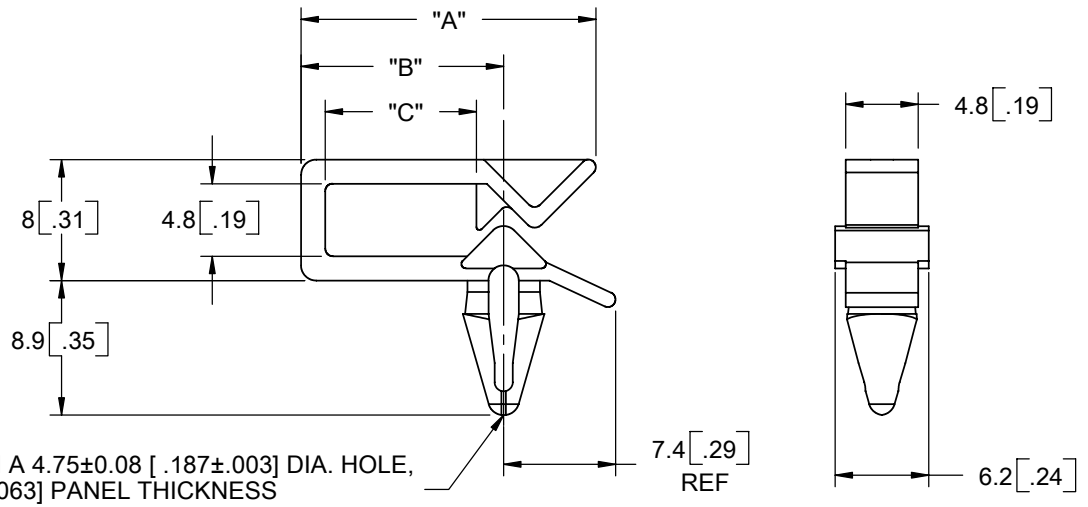

TO SNAP-LOCK IN A 4.75±0.08 [.187±.003] DIA. HOLE,  
IN A 0.5-1.6 [.020-.063] PANEL THICKNESS

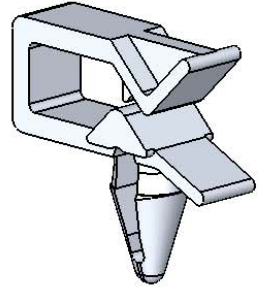

WS-SE2-1

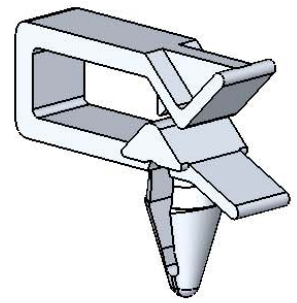

WS-SE2-2

- NOTES:
- MATERIAL: NYLON 6/6 UL 94 V-2 (RMS-01).  
NYLON 6/6 UL 94 V-0 (RMS-19), AVAILABLE  
BY SPECIAL ORDER ONLY.  
TO ORDER REPLACE "-01" WITH "-19"
  - COLOR: NATURAL.
  - ALTERNATE UNITS FOR REFERENCE ONLY.

TITLE: <b>WIRE SADDLE SIDE ENTRY</b>						DWG IN MM [IN]			
CREATED USING SOLIDWORKS		FILE #: WS-SE2-X	DWN: SK	APP: RT		FINAL			
GENERAL TOLERANCE UNLESS OTHERWISE NOTED		SHEET: 1 OF 1	SHEET SIZE: A	DT: 07/06/06	CHKD: SJ	PART #		PRINT TYPE	
±0.25 ANG.=±1°		RE: RICHCO, INC.		RICHCO, INC. ENG@RICHCO-INC.COM (773) 539-4060		SEE TABLE		CA	

REV.	DESCRIPTION	ENGR.	DATE
E	SEE ECN #1216 FOR CHANGES	SK	09/15/06
D	SEE ECN #1191 FOR CHANGES	SK	07/06/06
-	SEE ENGINEERING FOR REV A-C	-	---